



## 2" Large Single Port

Flangeless  
CL 150 – 600



**2" Large Single Port Flangeless Flowgrid® Valve with Series 20 Pilot**

### SECTIONAL VIEW

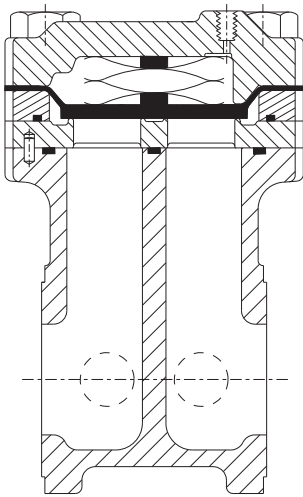

### OVERPRESSURE PROTECTION

The Flowgrid® Valve is bi-directional and has a full ANSI rating on both the inlet and outlet. Overpressure protection is required only if the pressure can exceed the flange or body rating.

The pilots, like most regulators, may have an outlet pressure rating lower than the inlet pressure rating. If this is the case then some external form of overpressure protection must be provided for the pilot.

Anytime the Flowgrid® valve or pilot system is exposed to pressure in excess of its rating it should be inspected for damage.

The 2" Large Single Port Flangeless Flowgrid® valve is simply a higher capacity version of the original 2" Single Port Valve. The space saving face-to-face dimension (4.187") is the same as the obsolete Model 82 and current Model 83 making the Flowgrid® valve an ideal replacement which offers in-line maintenance, Large Single Port and the Standard Port valves share the same Body, O-ring, Body Seal, and Main Spring. The Spring Case, diaphragm, Spacer and Throttle Plate are unique to this construction.

### SPECIFICATIONS

<b>Size</b>	2"
<b>Body Style</b>	Large Single Port (2")
<b>End Connections</b>	2" CL150, 300, 600 Flangeless
<b>Temperature</b>	Working -20°F to 150°F Emergency -40°F to 175°F
<b>Max. Operating Differential</b>	800 psi
<b>Max. Emergency Differential</b>	1000 psi
<b>Min. Differential</b>	Refer to graph on page 2
<b>Cracking Differential</b>	Refer to graph on page 2
<b>Max. Inlet Pressure</b>	1480 psig*
<b>Outlet Pressure Range</b>	Limited by Pilot
<b>Flow Direction</b>	Bi-Directional**
<b>Body Taps</b>	Two 1/4" - 18NPT

\* Limited by pilot or flange rating

\*\* Reverse flow by changing pilot connections and reversing spring case

### MATERIALS OF CONSTRUCTION

<b>Body &amp; Spring Case</b>	ASTM A 216 GR WCB Carbon Steel
<b>Throttle Plate</b>	17 - 4PH Stainless Steel or A515 Carbon Steel with ENC Coating
<b>Diaphragm</b>	Nitrile/Nylon*
<b>O-Ring &amp; Seals</b>	Nitrile, Optional (Viton)
<b>Bolting</b>	ASTM A 193 GR B-7 or Equal
<b>Spring</b>	301 Stainless Steel

\*Refer to diaphragm selection chart on page 2.

### STOCK NUMBERS

2" Large Single Port Flangeless Valve	Stock #	Weight
<b>150# Flangeless</b>	FG-35	28 lbs.
<b>300# Flangeless</b>	FG-35	28 lbs.
<b>600# Flangeless</b>	FG-35	28 lbs.

## DIMENSIONS

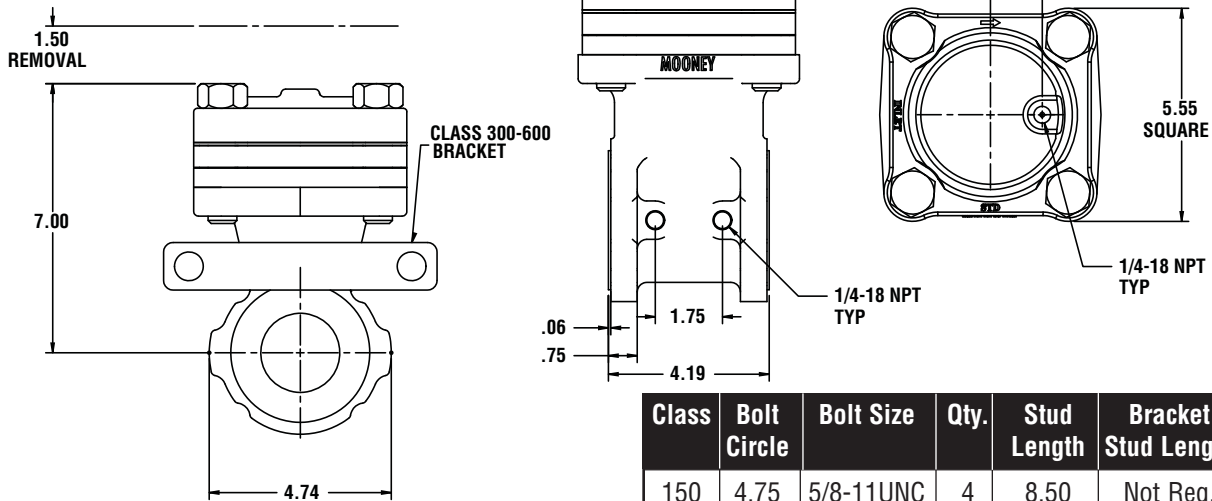

Class	Bolt Circle	Bolt Size	Qty.	Stud Length	Bracket Stud Length	Qty.
150	4.75	5/8-11UNC	4	8.50	Not Req.	Not Req.
300	5.00	5/8-11UNC	6	8.50	11.0	2
600	5.00	5/8-11UNC	6	8.50	11.0	2

**Stud Material:** A193 Grade B7    **Nut Material:** A194 Grade 2H

## FLOW COEFFICIENTS AND CONSTANTS

2" Large Single Port Type A Flangeless Valve				Swage Factor	
Percent Capacity	Cv	C1	Cg	1.5:1	2:1
100%	37	35	1300	0.98	0.96
75%	33	33	1083	0.98	0.97
50%	27	30	824	0.99	0.98
35%	20	30	590	1.00	1.00

**NOTE:** Allow a 5% factor of safety when calculating relief capacity

## MINIMUM PRESSURE DIFFERENTIAL VS. CAPACITY

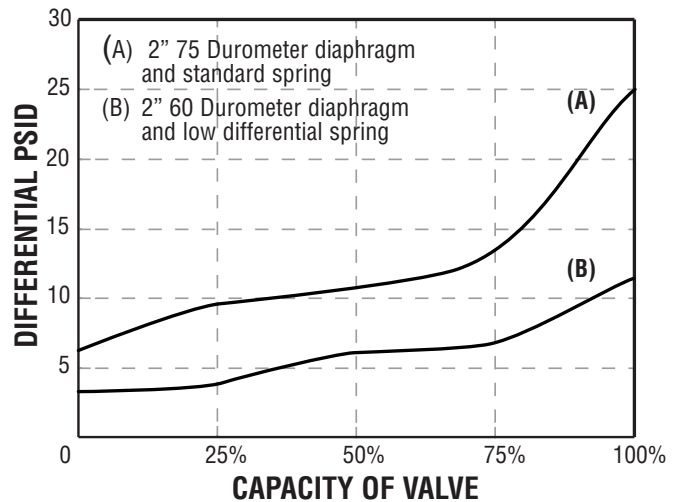

## DIAPHRAGM SELECTION

Compound	Temp. Range (Degrees F)	Maximum Differential	Characteristics	Recommended Applications
<b>75 Duro</b>	-20 to 150	800 psid	Best All Around Material	60 psid to Max. Differential
<b>60 Duro</b>	-25 to 150	300 psid	Best Shutoff at Low Differential Pressure	Low Differential (100 psid or less) or Low Temperature
<b>80 Duro High ACN</b>	-5 to 175	800 psid	Higher Abrasion and Swelling Resistance	High Differential (400 psid or higher) or Abrasive Conditions with Distillates
<b>80 Duro Low ACN</b>	-20 to 150	800 psid	Higher Abrasion Resistance and Low Temperature Flexibility	High Differential (400 psid or higher) or Abrasive Conditions at Low Temperatures